

ECON BELLOWS SEAL VALVES

Fig. 436



Operating and Instruction Manual for Bellows seal valves:
Fig. 436

Content

1. ERIKS operating companies
2. Product description
3. Requirements for maintenance staff
4. Transport and storage
5. Function
6. Application
7. Installation
8. Maintenance
9. Service and repair
10. Features
11. Troubleshooting
12. Removal

1. ERIKS operating companies

ECON bellows seal valves are being delivered by several ERIKS operating companies on a worldwide basis. In this manual these will be referred to as 'ERIKS', the individual terms of delivery of the ERIKS operating company having executed the order are applicable.

2. Product description

The ECON bellows seal valves are designed according EN-13789 and information in our latest catalogue or see our website www.eriks.com and should be used in accordance with the applicable pressure-temperature rating as stated on this website. ECON bellows seal valves are provided with casted markings according to EN 19. The marking makes the identification of the valve easier and contains:

- size (DN)
- pressure rating class
- body material marking
- arrow, indicating the medium flow direction
- heat numbers (when required)
- CE marking when applicable
- tag plate
- ECON logo

3. Requirements for maintenance staff

The staff assigned to assembly, operating and maintenance tasks should be qualified to carry out such jobs and in any circumstance, ensure personal safety

4. Transport and storage

Transport and storage should always be carried out with the discs complete closed and the valve should be protected against external forces, influence and destruction of the painting layer as well. The purpose of the painting layer is to protect the valve against rust, during transport and storage. The valves should be stored in an unpolluted space and should also be protected against all atmospheric circumstances. There should be taken care of the temperature and humidity in the room, in order to prevent condensate formation.

It is not allowed to fit lifting devices to connection holes, handwheel or stem.

5. Function

ECON bellows seal valves are designed to stop the flow of a medium. The bellow gives a fully sealed stem connection with zero leakages acc. to emission requirements of TÜV. The valve is closed by turning the hand wheel clockwise; don't use tools to increase the torque on the hand wheel.

6. Application

ECON bellows seal valves are widely used for steam, cold and hot water, thermal oil, air, gasses, etc. for shut off or connection of pipeline. The valves are designed for standard operating conditions. For the use of extreme conditions e.g. aggressive or abrasive media, it is recommended to mention this at the ordering stage, to verify whether the valve is suitable. The installation designer is responsible for the globe valve selection, suitable for the working conditions. The valves are unsuitable, without written permission of an ERIKS company, to apply for hazardous media as referred into Regulation (EC) No 1272/2008.

7. Installation

During the assembly of the standard ECON bellows seal valves, the following rules should be observed:

- the valves should be checked before installation if they have not any defects caused by transport and/or storage.
- make sure that the applied valves are suitable for the working conditions, medium used in the plant and the right system connections, according to pressure and temperature limits.
- protective hole plugs must be removed
- valves with fixed disc may be installed in any position but preferred is with the hand wheel in upright position.
- valves with balancing disc may **only** be installed in horizontal pipelines with the hand wheel upwards.
- during fitting, the proper flow direction has to be considered.
- the interior of the valve and pipeline must be free from foreign particles.
- the valve should be assembled in the pipeline in closed position, for a correct functioning, the valve must be stress free mounted between the flanges, supports must be arranged to prevent any additional stress, caused by the weight of the valve or the pipeline.
- bolted joints on the pipeline must not cause additional stress resulted from excessive tightening, user shall select proper bolts and gaskets according the working temperature, working pressure and medium.
- steam pipelines should be fitted in such a way to avoid condensate collection; in order to avoid water hammer steam traps should be applied.
- for easy operating, the clear distance around the hand wheel, shall not be less than 100MM
- before plant start-up, especially after repairs carried out, flash out the pipeline.

During the assembly of ECON bellows seal valves with balancing disc, the following extra rules should be observed:

- standard with balancing disc from size DN200 and larger
- there should be extra taken care of the flow direction marked on the valve; balancing valves must have the flow direction above the disc. This is the opposite direction of the flow direction of standard disc executions as flat disc!!

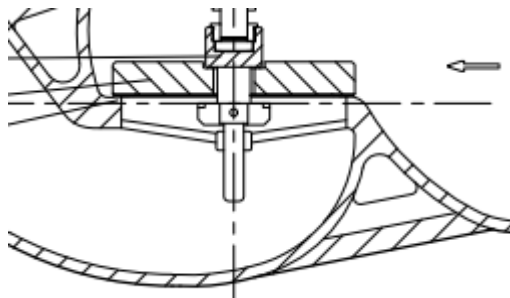

Example of balancing disc

8. Maintenance

Before starting any service jobs, make sure that the medium supply to the pipeline is cut off, pressure was decreased to ambient pressure, the pipeline is completely cleaned and ventilated and the plant is cooled down. Always keep safety instructions in mind and take all personal safety precautions.

During maintenance, the following rules should be observed:

- always keep personal safety precautions in mind and always use appropriate protection e.g. clothing, masks, gloves etc.
- be alert that the temperature still can be very high or low and can cause burns.
- keep the stem well greased
- check the valve on all possible leaking possibilities.
- check if all bolts and nuts, are still fastened.
- dust, grease and medium residual, must be frequently cleaned of the valve body and all moving parts, such as stem to maintain all operating functions.
- if there is a leakage across the stem, tighten the safety stuffing box till the leakage stops. The bellows seal valve must be taken out of the pipeline at next opportunity to check the interior of the valve. All necessary precautions as mentioned above have to be taken.
- if required, a new bellows seal valve must be installed, for safety reasons we recommend that the bellows seal valve only can be changed, when depressurized, drained and ventilated.
- check if the discs still open and close in a proper manner.
- the thickness of the body must be checked to ensure safety operation at an interval of at least three months.

9. Service and repair

All service and repair jobs should be carried out by authorized staff, using suitable tools and user shall use valve gasket, bolt and nut of the same size and material as the original one.

- welding (repair) and drilling of the valve is forbidden.
- it is forbidden to open the bonnet or replace the bolt, nut or safety packing when the valve is under pressure.
- before reassembling the bonnet, remember that the bearing surface must be cleaned and two new gaskets must be inserted. One above the bellow flange and one underneath the bellow flange. See drawing underneath.

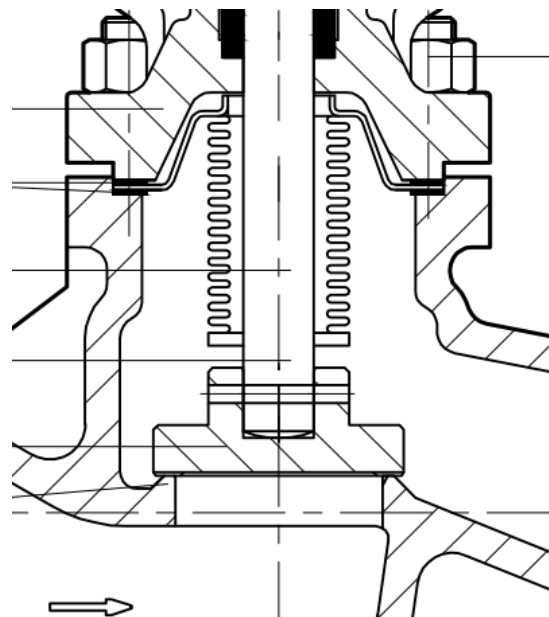

- tighten the hexagon nuts evenly crosswise in there for standard order.
- the bolts should be tighten evenly and crosswise by torque wrench.
- after replacement of the gasket, bolts or nuts, it is necessary to check the valve operation and tightness of all connections. A tightness test should be carried out.
- after installation, the valve should be checked and maintained periodically at least every 3 months, depending on the medium.

10. Features

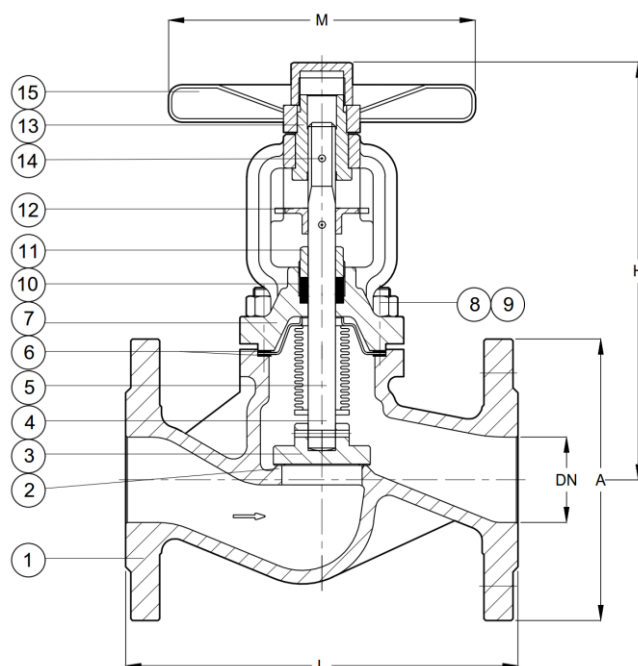

POS	NAME	MATERIAL
1	BODY	1.0619N
2	SEAT	1.0619N + STELLITE
3	DISC	13Cr
4	STEM	2Cr13
5	BELLOWS	1.4571 (316Ti)
6	BONNET GASKET (2x)	PURE GRAPHITE + SS304
7	BONNET	1.0619N
8	BOLT	ASTM A193 B7
9	NUT	ASTM A194 2H
10	GLAND PACKING	GRAPHITE MIN. 98%
11	THREADED GLAND	ASTM A105
12	LOCATER	SAE-AISI 1025
13	STEM NUT	COPPER
14	GREASE NIPPLE	COPPER
15	HANDWHEEL	SAE-AISI 1025

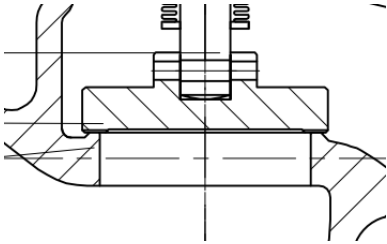

Standard fixed disc

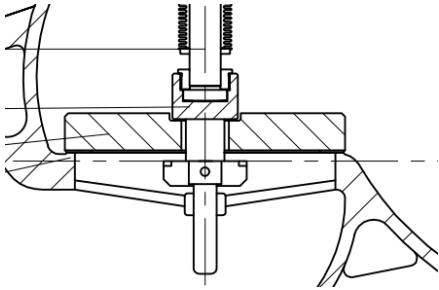

Balancing disc standard
for size DN200 and bigger

11. Troubleshooting

It is essential that the safety regulations are observed when identifying the fault.

Problem	Possible cause	Corrective measures
No flow	Flange dust caps were not removed	Remove dust caps
Little flow	Valve not completely open	Open valve completely
	Piping system clogged	Check piping system
Valve difficult to open	Stem dry	Grease stem by using the lubrication nipple
	Safety packing too tight	Loosen gland
	Wrong direction of rotation	Turn anti-clockwise to open
Leakage across the stem	Bellows seal damaged	Replace the valve or tighten gland till leakage stops. Replace the valve at earliest possibility!!
Leakage across valve seat	Valve not properly closed	Pull hand wheel tight without tools
	Seat damaged by foreign particles	Replace valve, or repair the seat
	Pressure difference too much	Apply valve with balancing disc. Check if the valve was assembled according to arrow direction on the valve
	Medium contaminated	Clean valve and install dirt screen
Leakage between bonnet flange	Bonnet bolts loose	Properly tighten bonnet nuts
	Bonnet gasket failure	Replace bonnet gaskets
Operating failure	Safety packing too tight	Loosen gland
	Thread of stem nut over worn	Replace the valve
	Stem bended	Rectify or replace the valve
Body and/or bonnet broken and leaking	Water hammer	Careful operation to prevent suddenly stopping pumping and rapidly shutting
	Broken because of freezing	Drain the water in the winter when valve is not used, or use proper isolation
Disc failed to open	Disc blocked	Don't use too much force
	Stem is overheated and blocks the disc	When the valve is closed and the pipeline is over-heated, rotate the hand wheel somewhat counter clockwise for unload at interval

12. Removal

All dismantled and rejected valves cannot be disposed with household waste. The valves are made of materials which can be re-used and should be delivered to designated recycling centres.